

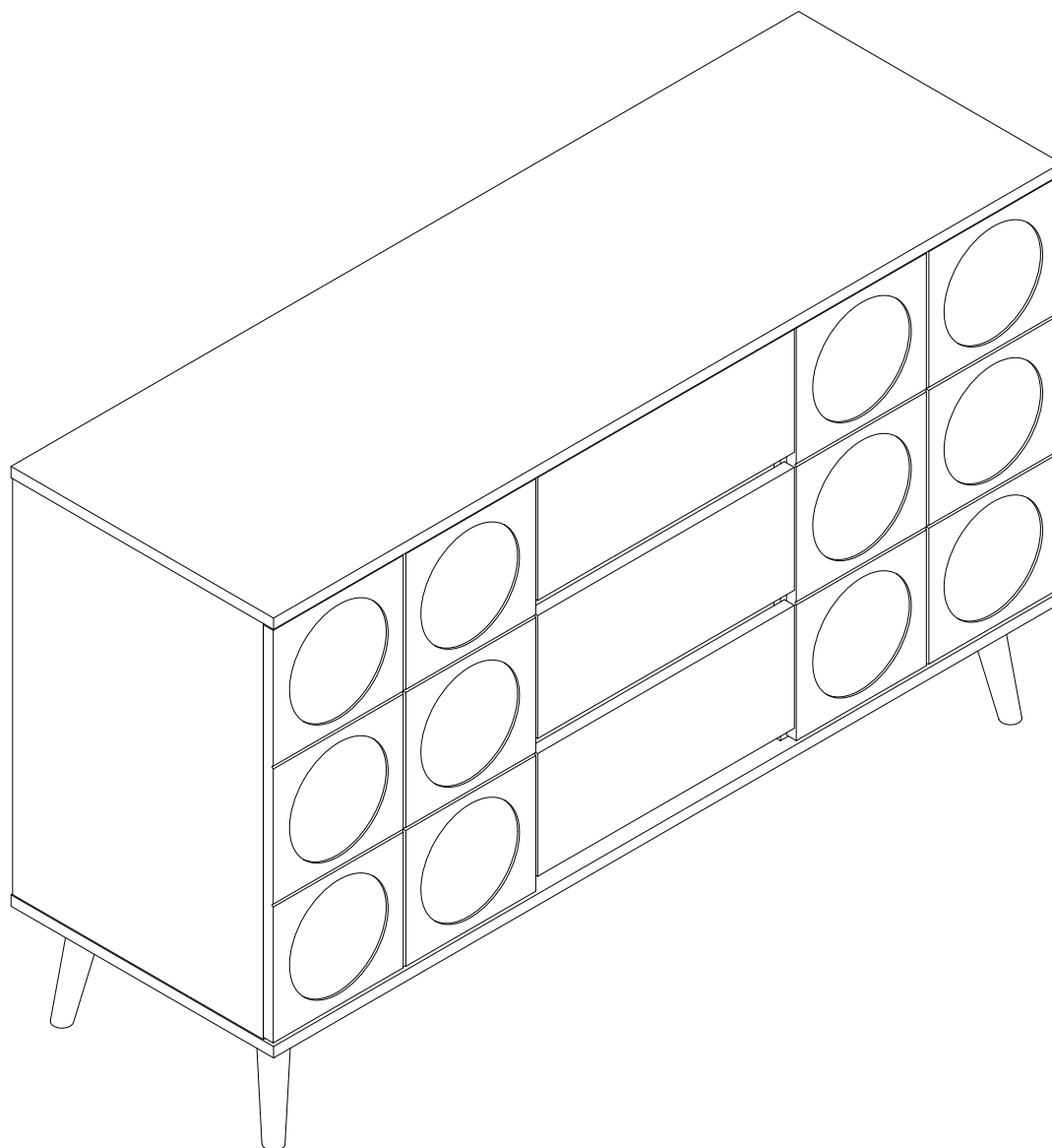



BOX-1 N657P221001W

BOX-2 N657P221002W

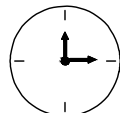
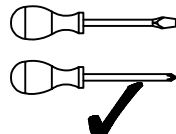

 2PERS	 60 MIN	Tool Required Not Provided	
			 
			

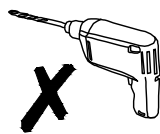

[DE]

Warnung: Lesen Sie die Anleitung vor dem Zusammenbau bitte vollständig durch. Überprüfen Sie, ob Sie alle auf den Seiten aufgeführten Komponenten und Werkzeuge haben.

Warnung: Legen Sie alle Teile auf eine ebene Fläche. Legen Sie eine weiche Decke oder Ähnliches darunter, um sie vor Kratzern oder Flecken zu schützen. Vermeiden Sie es, Komponenten über den Boden zu ziehen oder zu schieben.

Warnung: Überprüfen Sie regelmäßig alle Beschläge und Befestigungen, um sicherzustellen, dass sie sicher sind und um Unfälle zu vermeiden. Wenn Teile fehlen, kaputt, beschädigt oder abgenutzt sind, verwenden Sie das Produkt nicht weiter, bis es mit vom Hersteller autorisierten Teilen repariert wurde.

Warnung: Lassen Sie Kinder nicht auf die Möbel klettern, da dies zum Umkippen und zu schweren Verletzungen führen kann. Bauen Sie die Möbel außerhalb der Reichweite von Kindern zusammen.

Warnung: Stellen Sie die Möbel nicht in die Nähe von Feuerquellen oder heißen Gegenständen, um Brandgefahr zu vermeiden.

Warnung: Reinigen Sie die Möbel mit einem feuchten Tuch oder Alkohol. Verwenden Sie keine Reinigungsmittel mit ätzenden Chemikalien.

Warnung: Dieses Produkt ist mit einer Kippschutzvorrichtung ausgestattet. Bitte installieren Sie diese Vorrichtung unbedingt, um unnötige Verletzungen durch Umkippen zu vermeiden.

[EN]

Warning: Please read instructions fully before starting assembly. Check you have all the components and tools listed on pages.

Warning: Please place all parts on a flat surface. Place a soft blanket or similar underneath to protect against scratches or stains. Avoid dragging or sliding components across the floor.

Warning: Regularly check all fittings and fastenings to ensure they are secure and to prevent accidents. If any parts are missing, broken, damaged, or worn, discontinue use of the product until repairs have been made using factory authorized parts.

Warning: Do not allow children to climb on the furniture as this may result in tipping and serious personal injury. Assemble the furniture away from the reach of children.

Warning: Do not place furniture close to fire sources or high-temperature objects to avoid the risk of fire.

Warning: Clean furniture with a damp cloth or alcohol, avoid using cleaning agents containing corrosive chemicals.

Warning: This product is equipped with an anti-tilt device. Please be sure to install this device to prevent unnecessary injuries caused by tipping.

[FR]

Avertissement : Veuillez lire entièrement les instructions avant de commencer l'assemblage. Vérifiez que vous disposez de tous les composants et outils répertoriés sur les pages.

Avertissement : Veuillez placer toutes les pièces sur une surface plane. Placez une couverture douce ou similaire en dessous pour les protéger des rayures ou des taches. Évitez de faire glisser les composants sur le sol.

Avertissement : Vérifiez régulièrement tous les raccords et fixations pour vous assurer qu'ils sont bien fixés et pour éviter les accidents. Si des pièces manquent, sont cassées, endommagées ou usées, cessez d'utiliser le produit jusqu'à ce que des réparations aient été effectuées à l'aide de pièces autorisées par l'usine.

Avertissement : Ne laissez pas les enfants grimper sur les meubles car cela pourrait entraîner un basculement et des blessures graves. Assemblez les meubles hors de portée des enfants.

Avertissement : Ne placez pas les meubles à proximité de sources de feu ou d'objets à haute température pour éviter tout risque d'incendie.



Avertissement : Nettoyez les meubles avec un chiffon humide ou de l'alcool, évitez d'utiliser des produits de nettoyage contenant des produits chimiques corrosifs.

Avertissement : Ce produit est équipé d'un dispositif anti-basculement. Assurez-vous d'installer ce dispositif pour éviter les blessures inutiles causées par un basculement.

[IT]

Attenzione: leggere attentamente le istruzioni prima di iniziare il montaggio. Verificare di avere tutti i componenti e gli strumenti elencati nelle pagine.

Attenzione: posizionare tutte le parti su una superficie piana. Posizionare una coperta morbida o simile sotto per proteggere da graffi o macchie. Evitare di trascinare o far scivolare i componenti sul pavimento.

Attenzione: controllare regolarmente tutti i raccordi e i dispositivi di fissaggio per assicurarsi che siano sicuri e per prevenire incidenti. Se alcune parti sono mancanti, rotte, danneggiate o usurate, interrompere l'uso del prodotto fino a quando non siano state eseguite le riparazioni utilizzando parti autorizzate dalla fabbrica.

Attenzione: non consentire ai bambini di arrampicarsi sui mobili poiché ciò potrebbe causare ribaltamenti e gravi lesioni personali. Montare i mobili lontano dalla portata dei bambini.

Attenzione: non posizionare i mobili vicino a fonti di fuoco o oggetti ad alta temperatura per evitare il rischio di incendio.

Attenzione: pulire i mobili con un panno umido o alcol, evitare di utilizzare detergenti contenenti sostanze chimiche corrosive.

Attenzione: questo prodotto è dotato di un dispositivo antiribaltamento. Assicurarsi di installare questo dispositivo per prevenire lesioni inutili causate dal ribaltamento.

[ES]

Advertencia: Lea las instrucciones completamente antes de comenzar el montaje. Compruebe que tiene todos los componentes y herramientas que se enumeran en las páginas.

Advertencia: Coloque todas las piezas sobre una superficie plana. Coloque una manta suave o algo similar debajo para protegerlas de rayones o manchas. Evite arrastrar o deslizar los componentes por el piso.

Advertencia: Verifique regularmente todos los accesorios y fijaciones para asegurarse de que estén seguros y evitar accidentes. Si falta alguna pieza, está rota, dañada o desgastada, deje de usar el producto hasta que se hayan realizado las reparaciones con piezas autorizadas de fábrica.

Advertencia: No permita que los niños se suban a los muebles, ya que esto puede provocar que se vuelquen y lesiones personales graves. Monte los muebles fuera del alcance de los niños.

Advertencia: No coloque los muebles cerca de fuentes de fuego u objetos de alta temperatura para evitar el riesgo de incendio.

Advertencia: Limpie los muebles con un paño húmedo o alcohol, evite usar agentes de limpieza que contengan químicos corrosivos.

Advertencia: Este producto está equipado con un dispositivo antivuelco. Asegúrese de instalar este dispositivo para evitar lesiones innecesarias causadas por vuelcos.

Importeur	Decobus Handel GmbH		
Adresse	Innungsstraße 9, 21244 Buchholz, Deutschland		
URL	https://www.decobusgroup.de		
Hersteller	Shouguang Rema Wood Co.,LTD		
Adresse	Daotian Town, Shouguang City, Weifang, Shandong, China		
Email/URL	https://www.remawood.com		
<table border="1"><tr><td>EC</td><td>REP</td></tr></table>	EC	REP	Decobus Handel GmbH Innungsstraße 9, 21244 Buchholz, Deutschland https://www.decobusgroup.de
EC	REP		

EN

Dear customer,
Thank you for purchasing this product. So that your appliance serves you well, please read all the instructions in this user's manual. If you have any questions, please contact our customer care center.

FR

Cher client,
Nous vous remercions d'avoir acheté ce produit. Afin que vous puissiez profiter pleinement de votre appareil, veuillez lire toutes les instructions de ce manuel d'utilisation. Si vous avez la moindre question, veuillez contacter notre centre d'assistance à la clientèle.

DE

Sehr geehrter Kunde,
Vielen Dank, dass Sie dieses Produkt erworben haben. Damit Ihr Gerät Ihnen gute Dienste leistet, lesen Sie bitte alle Hinweise in diesem Benutzerhandbuch. Wenn Sie Fragen haben, wenden Sie sich bitte an unser Kundendienstzentrum.

ES

Queridos clientes,
Gracias por comprar este producto. Para que su electrodoméstico le sirva mejor, lea todas las instrucciones de este manual del usuario. Si tiene alguna pregunta, comuníquese con nuestro Centro de Atención al Cliente.

IT

Caro Cliente,
Grazie per aver acquistato questo prodotto. Per servirti meglio con questo apparecchio ti prego di leggere tutte le istruzioni in presente manuale utente. In caso di dubbio, si prega di contattare il nostro centro assistenza clienti.

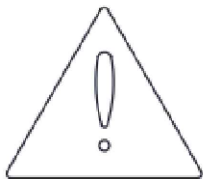

our product will be delivered to you in 2 packages. the delivery times of these 2 packages may differ, please be patient and thank you for your understanding.
unser produkt wird ihnen in 2 paketen geliefert. die lieferzeiten dieser 2 pakete können abweichen, bitte haben sie etwas geduld und vielen dank für ihr verständnis.

EN

WARNING

Serious or fatal injury may occur from unexpected assembly or use.

1. During the assembly process, keep all parts away from babies or children.
2. Always securely fix this product to the wall. Make sure the wall area to be drilled is free from hidden electrical wires, water and gas pipes.
3. Use of tip-over restraints may only reduce, but not eliminate the risk of tip-over.
4. Unless specially designed to accommodate, do not set heavy objects on top of this product.
5. Place the heaviest items on the lowest shelf.
6. Never allow children to climb or bang on drawers, doors or shelves.

DE

WARNUNG

Bei unerwarteter Montage oder Verwendung können schwere oder tödliche Verletzungen auftreten.

1. Legen Sie in den Montageprozess alle Teile weg von Babys oder Kindern.
2. Stellen Sie sicher, dass der gebohrte Wandbereich frei von verborgenen Stromkabeln, Wasser- und Gasleitungen ist, wenn Sie dieses Produkt an der Wand befestigen.
3. Die Verwendung von Kippsicherungen kann die Gefahr eines Kippens nur verringern, jedoch nicht beseitigen.
4. Setzen Sie bitte keine schweren Gegenstände auf dieses Produkt, es sei denn, dass das Produkt speziell für die Unterbringung konzipiert wird.
5. Legen Sie bitte die schwersten Gegenstände auf das unterste Regal.
6. Erlauben Sie nie Kindern, auf Schubladen, Türen oder Regale zu klettern oder zu knallen.

FR

WARNUNG

Les blessures graves ou mortelles peuvent survenir en raison d'un assemblage ou d'une utilisation imprévus.

1. Pendant le processus d'assemblage, gardez toutes les pièces hors de portée des bébés et des enfants.
2. Fixez toujours solidement ce produit au mur et assurez-vous que la zone du mur à percer est exempte de fils électriques cachés, d'eau et de conduites de gaz.
3. L'utilisation de dispositifs de retenue anti-basculement peut seulement réduire, mais ne peut pas éliminer le risque de basculement.
4. À moins d'être spécialement conçu à cet effet, ne placez pas d'objets lourds sur le dessus de ce produit.
5. Placez les objets les plus lourds sur l'étagère la plus basse.
6. Ne laissez jamais les enfants grimper ou frapper les tiroirs, les portes ou les étagères.

ES

ADVERTENCIA

Puede producirse lesiones graves o fatales debido a un montaje o uso inesperado.

1. Durante el proceso de montaje, mantenga todas las piezas alejadas de bebés o niños.
 2. Siempre fije este producto de forma segura a la pared. Asegúrese de que el área de la pared donde se realizará la perforación esté libre de cables eléctricos, tuberías de agua y gas ocultas.
 3. El uso de dispositivos de sujeción para evitar vuelcos solo puede reducir, pero no eliminar, el riesgo de vuelco.
 4. A menos que esté especialmente diseñado para ello, no coloque objetos pesados encima de este producto.
 5. Coloque los objetos más pesados en el estante más bajo.
- Nunca permita que los niños trepen o golpeen los cajones, puertas o estantes.

IT

ATTENZIONE

Possono verificarsi lesioni gravi o fatali a causa di un assemblaggio o uso imprevisto.

1. Durante il processo di assemblaggio, tenere tutte le parti lontane da bambini o neonati.
2. Fissare sempre saldamente questo prodotto alla parete. Assicurarsi che l'area della parete da perforare sia priva di cavi elettrici nascosti, tubi dell'acqua e del gas.
3. L'uso di dispositivi di fissaggio anti-ribaltamento può solo ridurre, ma non eliminare, il rischio di ribaltamento.
4. A meno che non sia appositamente progettato per farlo, non posizionare oggetti pesanti sopra questo prodotto.
5. Posizionare gli oggetti più pesanti sullo scaffale più basso.
6. Non permettere mai ai bambini di arrampicarsi o sbattere su cassetti, porte o scaffali.

USING CAM LOCK AND QUICKFIT

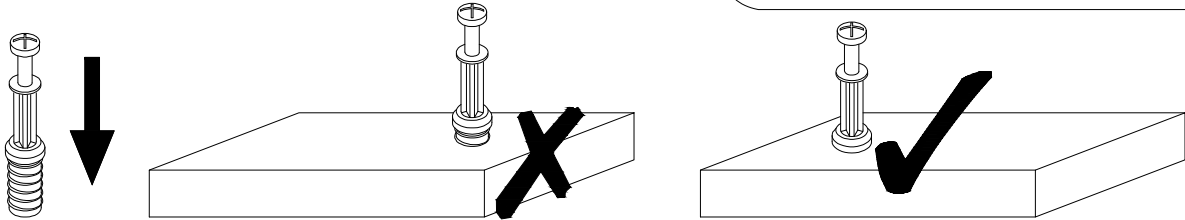

EN QUICKFIT: Tighten quickfit until shoulder is flush with panel. Do not overtighten or undertighten.

FR RACCORD RAPIDE: Faites serrer le raccord rapide jusqu'à ce que l'épaule soit parfaitement encastrée dans le panneau. Il ne faut ni trop serrer ni insuffisamment serrer.

ES QUICKFIT: Apriete quickfit hasta que el hombro se descargue con el panel. NO lo sobreapriete ni lo apriete poco.

DE QUICKFIT: Ziehen Sie den Quickfit fest, bis die Schulter mit der Platte bundig ist. Bitte nicht zu fest oder zu schwach anziehen.

IT_MONTAGGIO RAPIDO: Stringere il montaggio rapido fino a quando la spalla è a filo con il pannello, non stringere troppo o troppo poco.

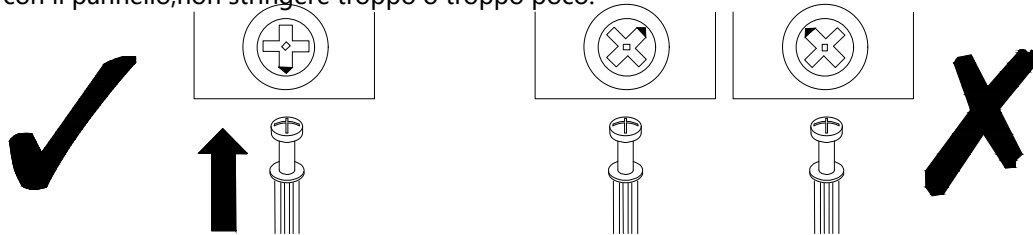

EN CAM LOCK: When fitting cam lock, ensure starting position is correct before you insert connecting quickfit.

FR SERRURE BATTEUSE: Avant d'insérer la serrure batteuse, veillez à la bonne orientation avant d'insérer le raccord rapide.

ES CIERRE DE LA CAMARA: Cuando instale el cierre de la cámara, asegúrese de que la posición de inicio es correcta antes de que inserte el quickfit conector.

DE_CAM-LOCK: Achten Sie bei der Montage des Cam-Locks auf die richtige Ausgangsposition, bevor Sie den Quickfit einsetzen.

IT_BLOCCAGGIO A CAMMA: Quando si monta il bloccaggio a camma, assicurarsi che la posizione iniziale sia corretta prima di inserire il montaggio rapido di collegamento.

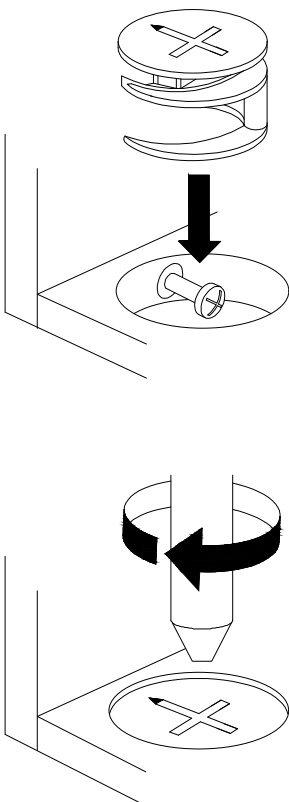

EN Quickfit head should be in the centre of the cam lock when the two panels are joined.

Cam lock should be inserted before quickfit.

FR_Lorsque les deux panneaux sont assemblés, la tête du raccord rapide doit reposer au centre de la serrure batteuse.

Il faut insérer la serrure batteuse avant le raccord rapide.

ES_El cabezal del quickfit debe estar en el centro del cierre de la cámara cuando se unan los dos paneles.

Se debe insertar el cierre de la cámara antes que el quickfit.

DE_Der Quickfit-Kopf sollte sich in der Mitte des Cam-Locks befinden, wenn die beiden Platten zusammengefügt sind.

Der Cam-Lock sollte vor dem Quickfit eingesetzt werden.

IT_La testa del montaggio rapido deve trovarsi al centro del bloccaggio a camma quando i due pannelli sono uniti.

Il Bloccaggio a Camma deve essere inserito prima del montaggio rapido.

EN Turn cam lock clockwise to tighten.

FR Faites tourner la serrure batteuse dans le sens des aiguilles d'une montre pour la resserrer.

ES Gire el cierre de la cámara en sentido horario para apretarlo.

DE Drehen Sie den Cam-Lock im Uhrzeigersinn, um ihn festzuziehen.

IT Ruotare il bloccaggio a camma in senso orario per stringere.

EN It may be necessary to adjust the hinges so that the doors align. Use the instructions below as a guide.

FR Il est parfois nécessaire d'ajuster les charnières pour un meilleur alignement des portes. Servez-vous des instructions ci-dessous comme guide.

ES Puede que sea necesario ajustar los quicios de forma que se alineen las puertas. Use las instrucciones que aparecen debajo como guía.

DE_Möglicherweise müssen Sie die Scharniere so einstellen, dass die Türen ausgerichtet sind. Verwenden Sie die nachstehenden Anweisungen als Leitfaden.

IT_Potrebbe essere necessario regolare le cerniere in modo che le porte siano allineate. Per fare ciò attenersi alle istruzioni sottostanti.

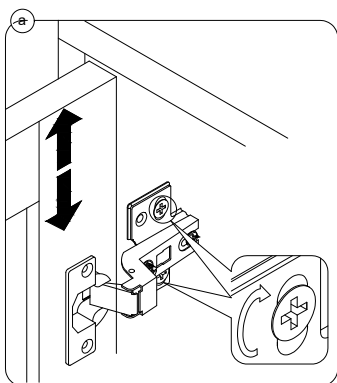

EN To adjust the door vertically loosen the screw as shown and move up and down as needed.

FR Si vous souhaitez régler la porte verticalement, desserrez la vis comme indiqué et déplacez la porte de haut en bas selon les besoins.

ES Para ajustar la puerta verticalmente afloje el tornillo tal y como se muestra y muevalo hacia arriba o hacia abajo según sea necesario.

DE Um die Tür vertikal auszurichten, lösen Sie die Schraube wie abgebildet und bewegen Sie sie nach Bedarf nach oben oder nach unten.

IT Per allineare la porta verticalmente allentare la vite come mostrato e spostarla in alto o in basso secondo necessità.

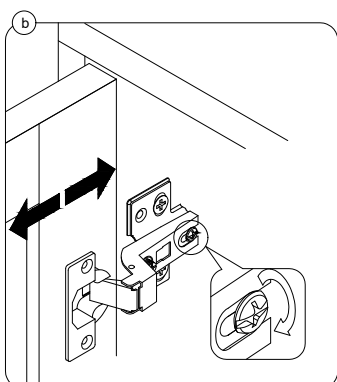

EN To adjust the gap from the door to the main frame turn the screw clockwise or anti-clockwise as needed.

FR Si vous souhaitez ajuster l'écart entre la porte et le cadre principal, tournez la vis dans le sens des aiguilles d'une montre ou dans le sens inverse, si nécessaire.

ES Para ajustar el espacio desde la puerta al marco principal, gire el tornillo en sentido horario o antihorario, según se necesite.

DE Um den Abstand von der Tür zum Hauptrahmen auszurichten, drehen Sie die Schraube je nach Bedarf im oder gegen den Uhrzeigersinn.

IT Per regolare lo spazio tra la porta e il telaio principale, avvitare o svitare la vite secondo necessità.

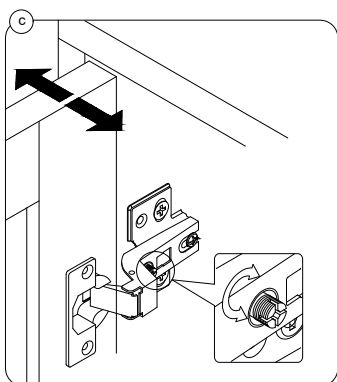

EN To adjust the door laterally adjust the screw as shown by turning clockwise or anti-clockwise.

FR Si vous souhaitez ajuster la porte latéralement, ajustez la vis comme indiqué en tournant dans le sens des aiguilles d'une montre ou dans le sens inverse des aiguilles d'une montre.

ES Para ajustar la puerta lateralmente ajuste el tornillo tal y como se muestra girandolo en sentido horario y antihorario.

DE Um die Tür seitlich auszurichten, stellen Sie bitte die Schraube wie abgebildet durch Drehen im oder gegen den Uhrzeigersinn ein.

IT Per allineare la porta lateralmente regolare la vite come mostrato, avvitandola o svitandola.

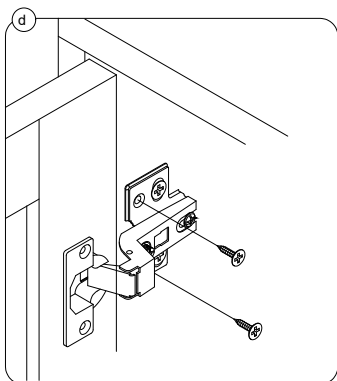

EN Please fix other screws

FR Merci de serrer les autres vis.

ES Fije los demás tornillos

DE Befestigen Sie bitte die anderen Schrauben

IT Fissare le altre viti

N657P221001W

①

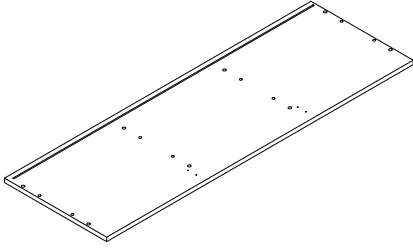

1

②

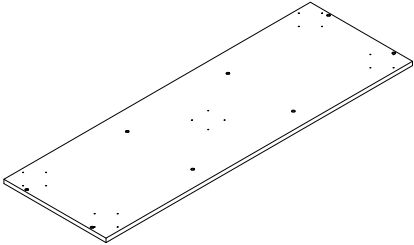

1

③

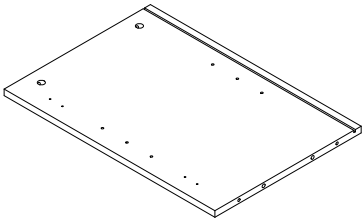

1

④

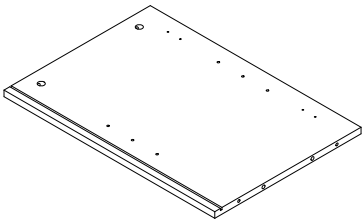

1

⑤

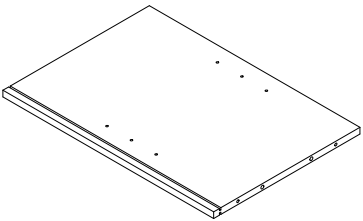

1

⑥

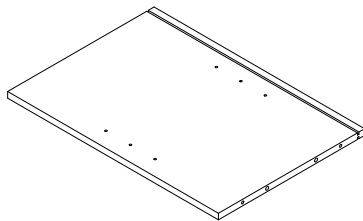

1

N657P221002W

⑦

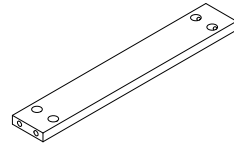

3

⑧

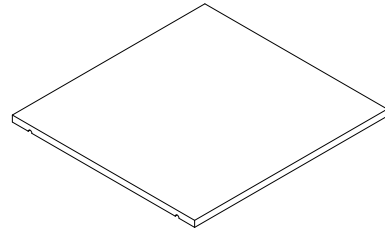

2

⑨

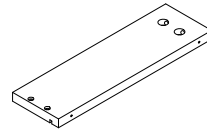

3

⑩

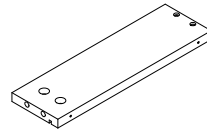

3

⑪

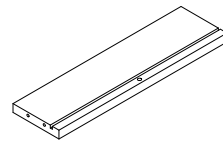

3

⑫

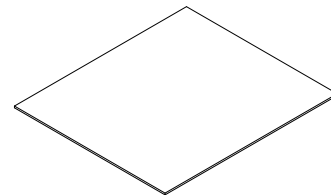

3

⑬

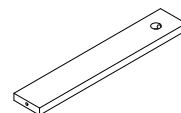

3

N657P221002W

14

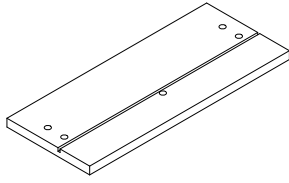

3

15

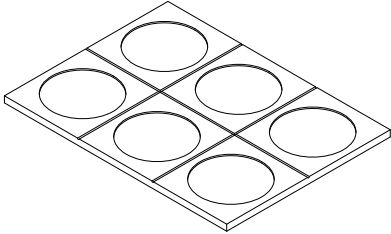

2

16

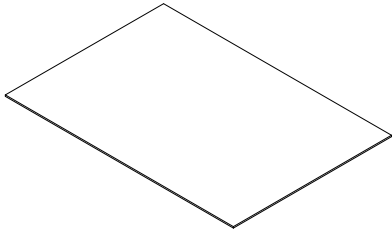

3

17

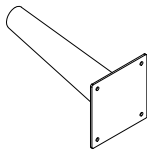





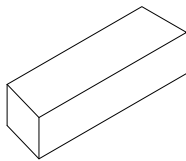



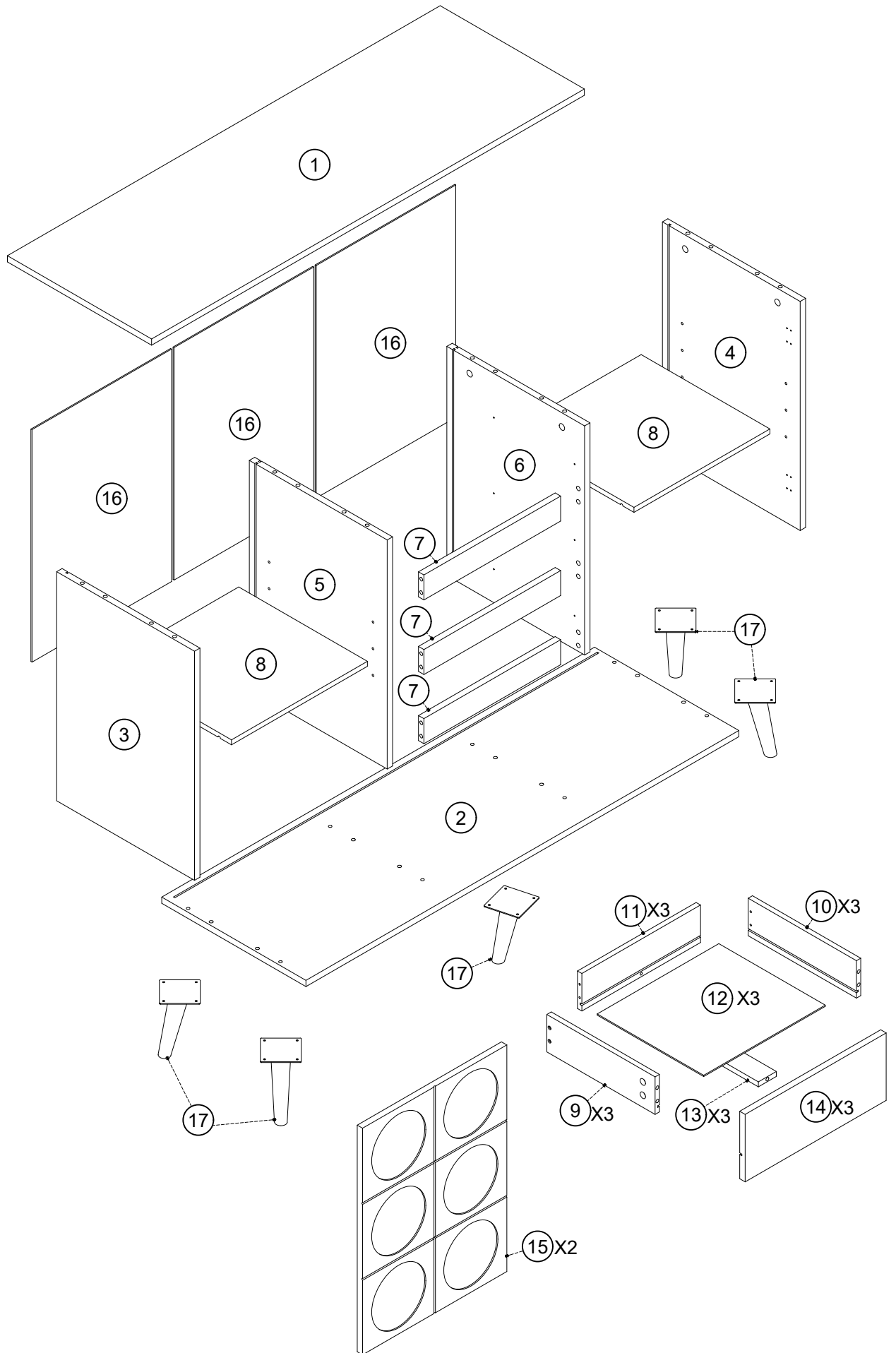

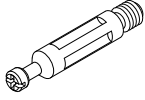
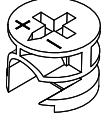
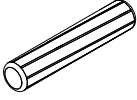
5

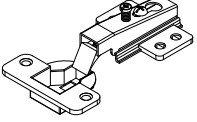
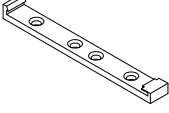
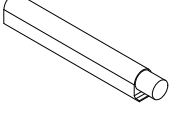
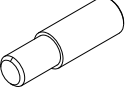
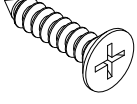
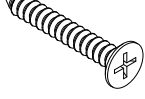
Hardware Box



1



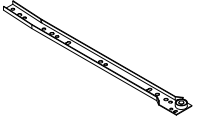
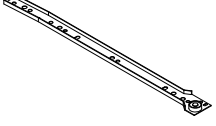
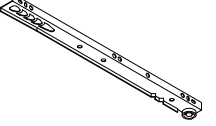
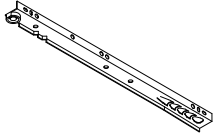

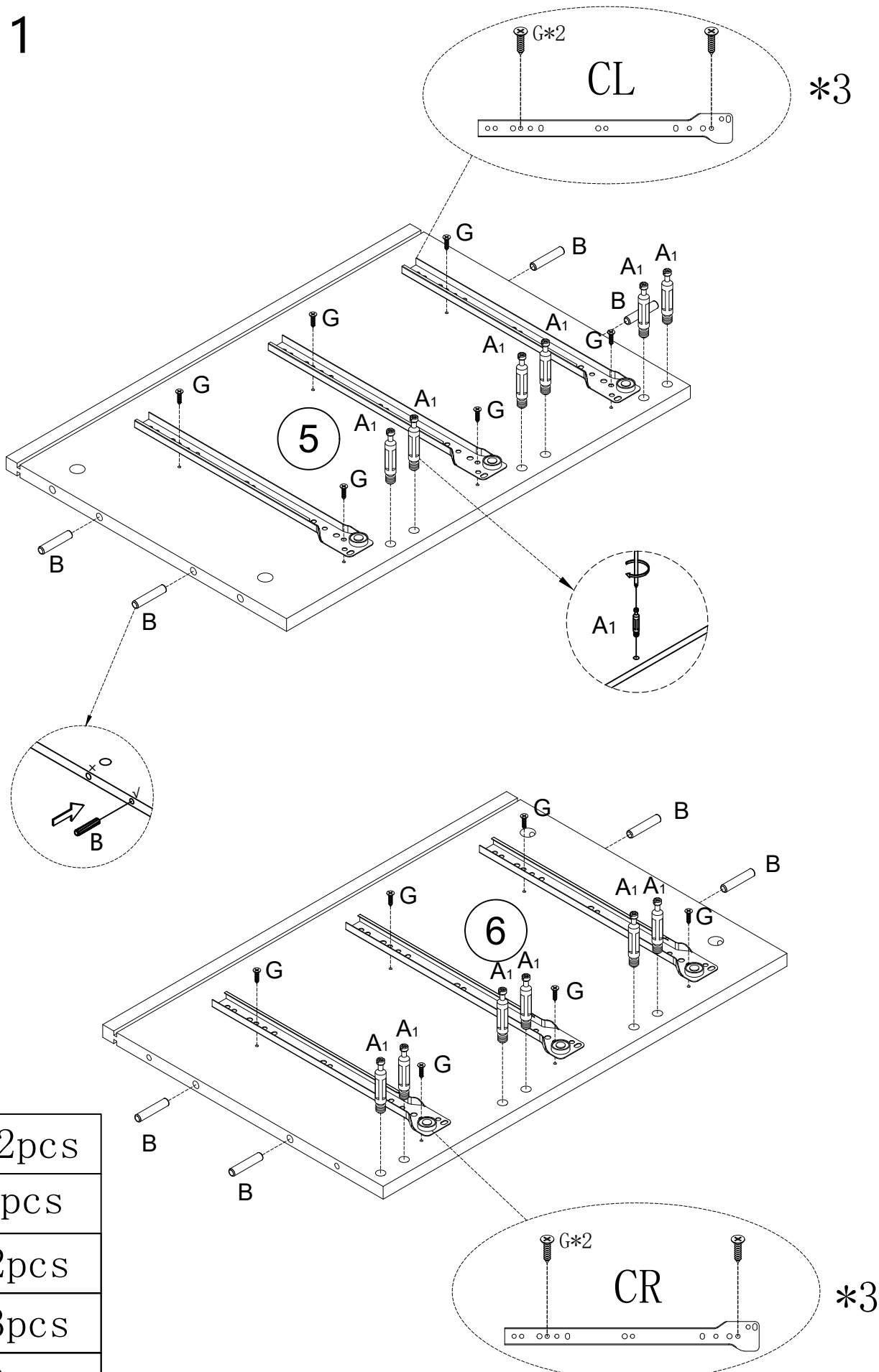

<p>A₁</p>  <p>Ø6*40 35PCS</p>	<p>A₂</p>  <p>Ø15*9.5 35PCS</p>	<p>B</p>  <p>Ø8*40 16PCS</p>	<p>C</p>  <p>M7*50 8PCS</p>	
<p>D</p>  <p>4PCS</p>	<p>E₁</p>  <p>2PCS</p>	<p>E₂</p>  <p>2PCS</p>	<p>F</p>  <p>8PCS</p>	
<p>G</p>  <p>M3.5*14 72PCS</p>	<p>H</p>  <p>M3.5*35 15PCS</p>	<p>I</p>  <p>20PCS</p>	<p>K</p>  <p>12PCS</p>	
<p>J</p> <p>J₁  J₂  J₃=3.5*14 </p> <p>J₄=3.5*30  J₅  2PCS</p>			<p>L</p>  <p>M3.5*12 12PCS</p>	<p>CLX3</p>  <p>L300mm</p>
<p>CRX3</p>  <p>L300mm</p>	<p>DLX3</p>  <p>L300mm</p>	<p>DRX3</p>  <p>L300mm</p>		

Schritt 1

Step 1



	A ₁ x12pcs
	Bx8pcs
	Gx12pcs
	CLx3pcs
	CRx3pcs

Schritt 2 Step 2

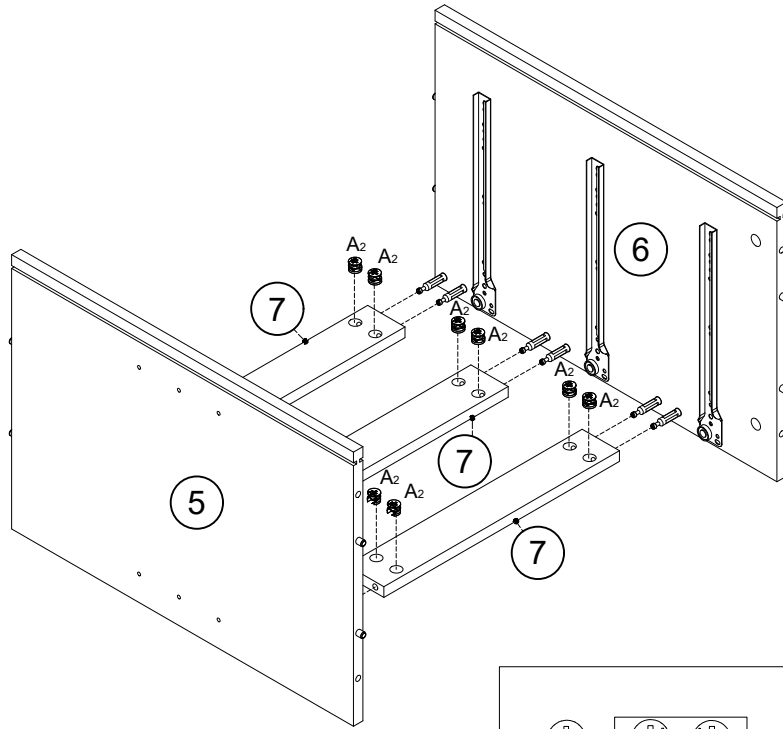

A₂x12pcs

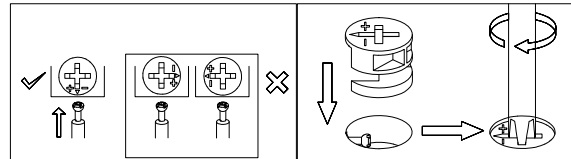

Schritt 3 Step 3

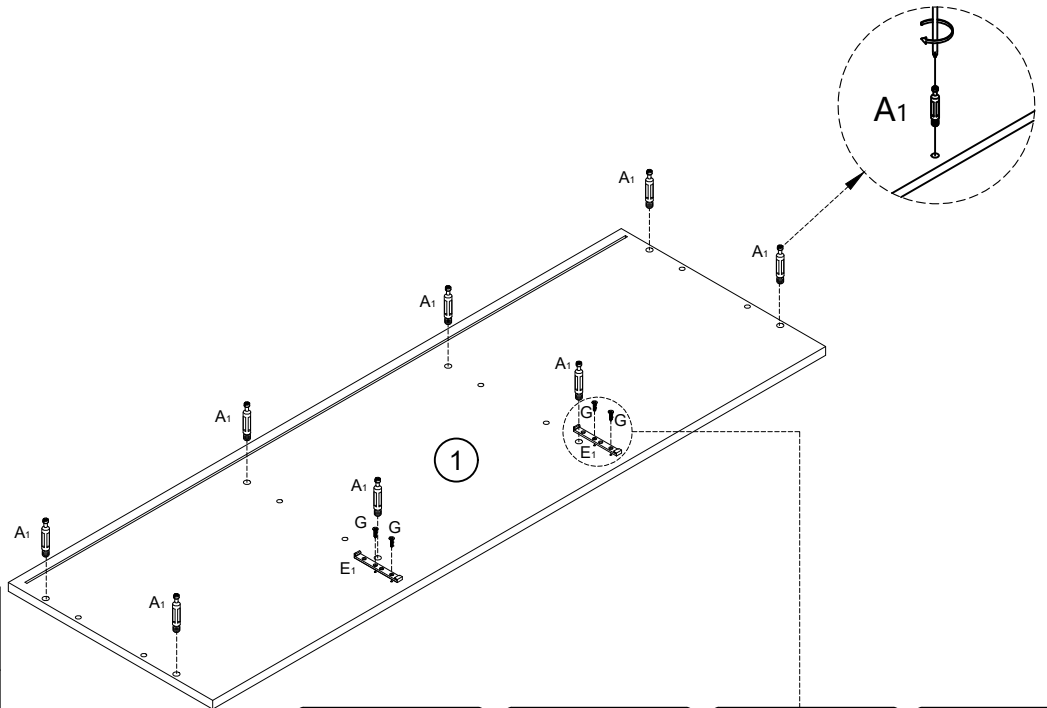

A₁x8pcs



Gx4pcs



E₁x2pcs



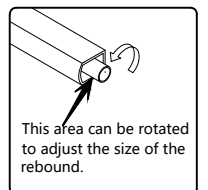
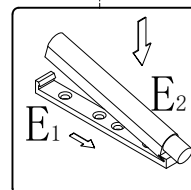
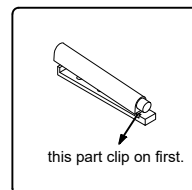
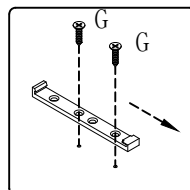

E₂x2pcs

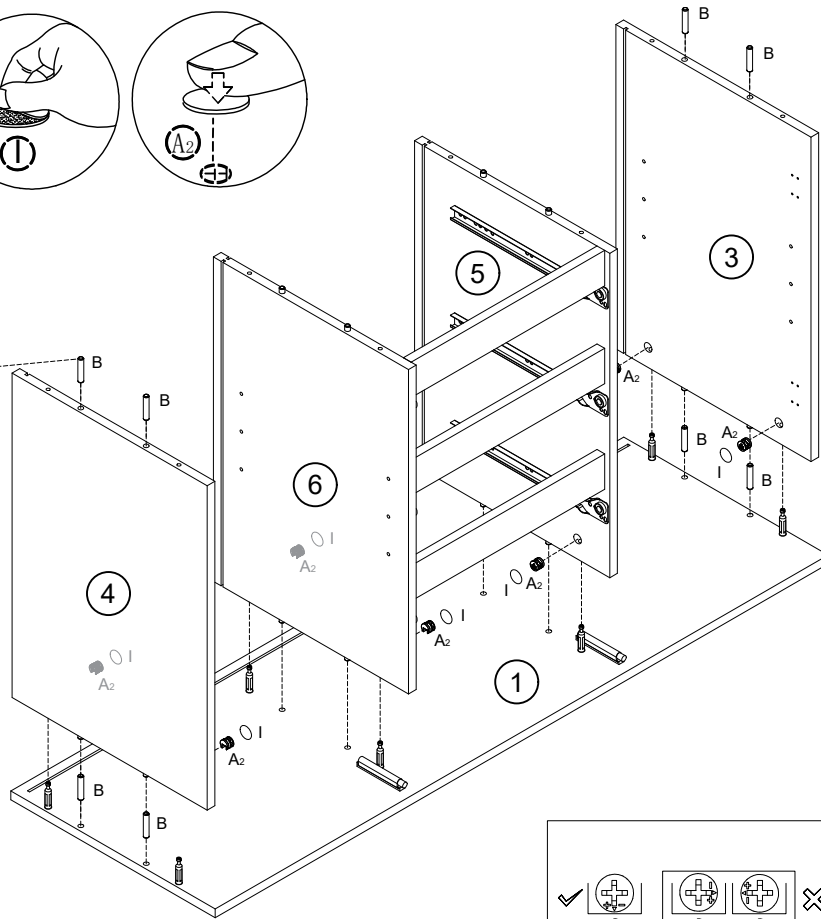
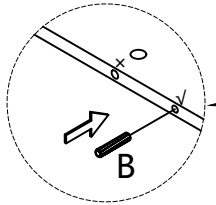
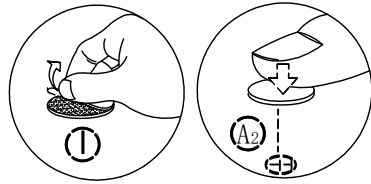

Schritt 4 Step 4



	A ₂ x8pcs
	Bx8pcs
	Ix8pcs

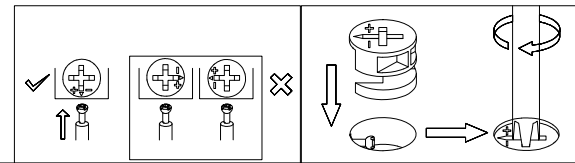

Schritt 5 Step 5

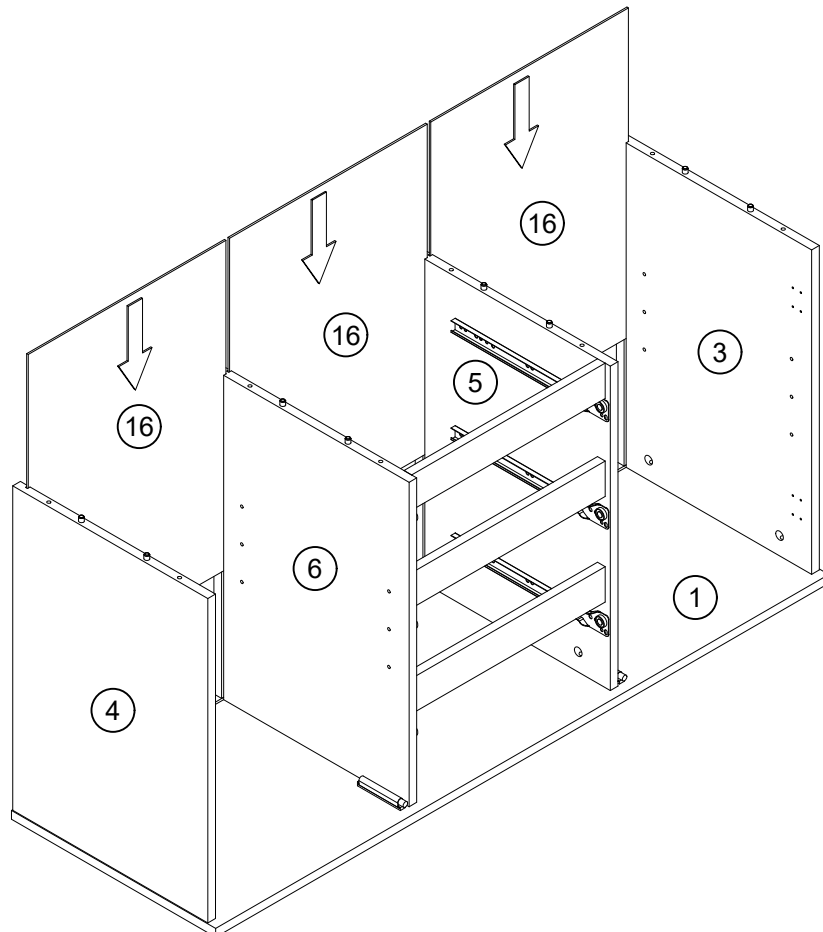

Schritt 6 Step 6

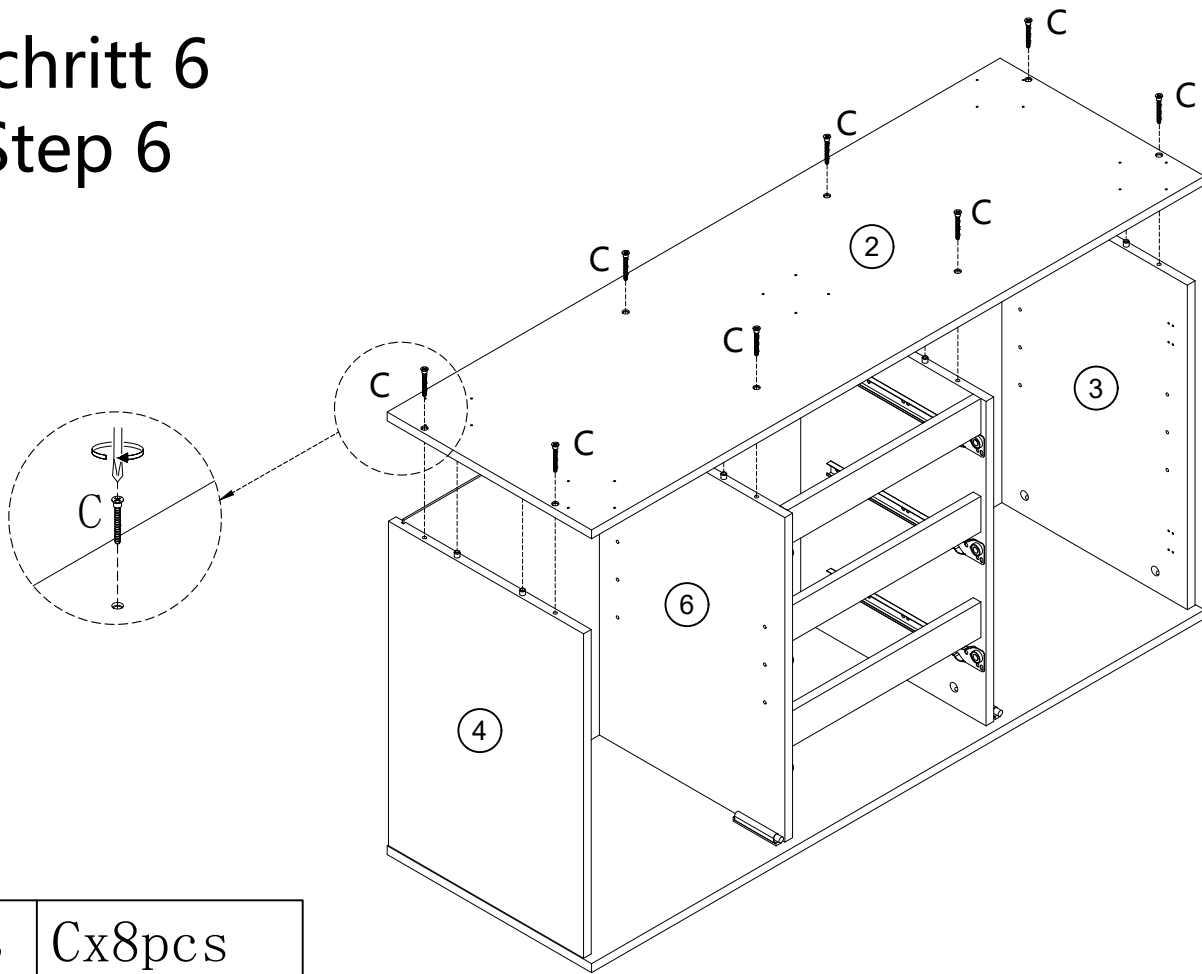

Cx8pcs

Schritt 7 Step 7

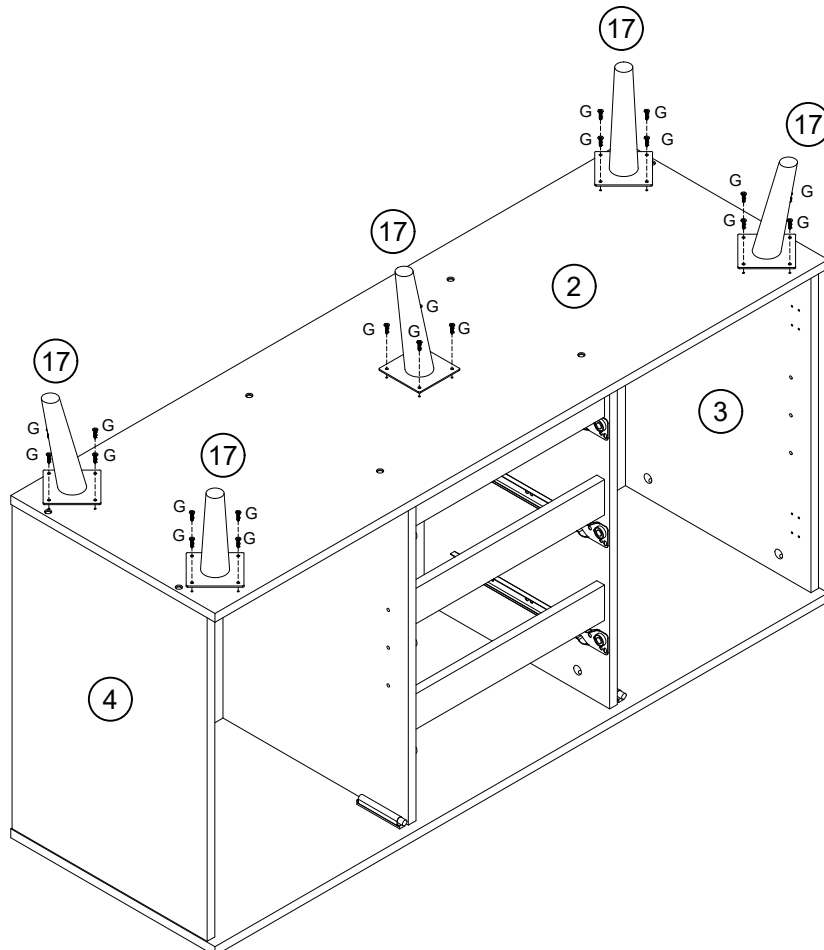



Gx20pcs

Schritt 8

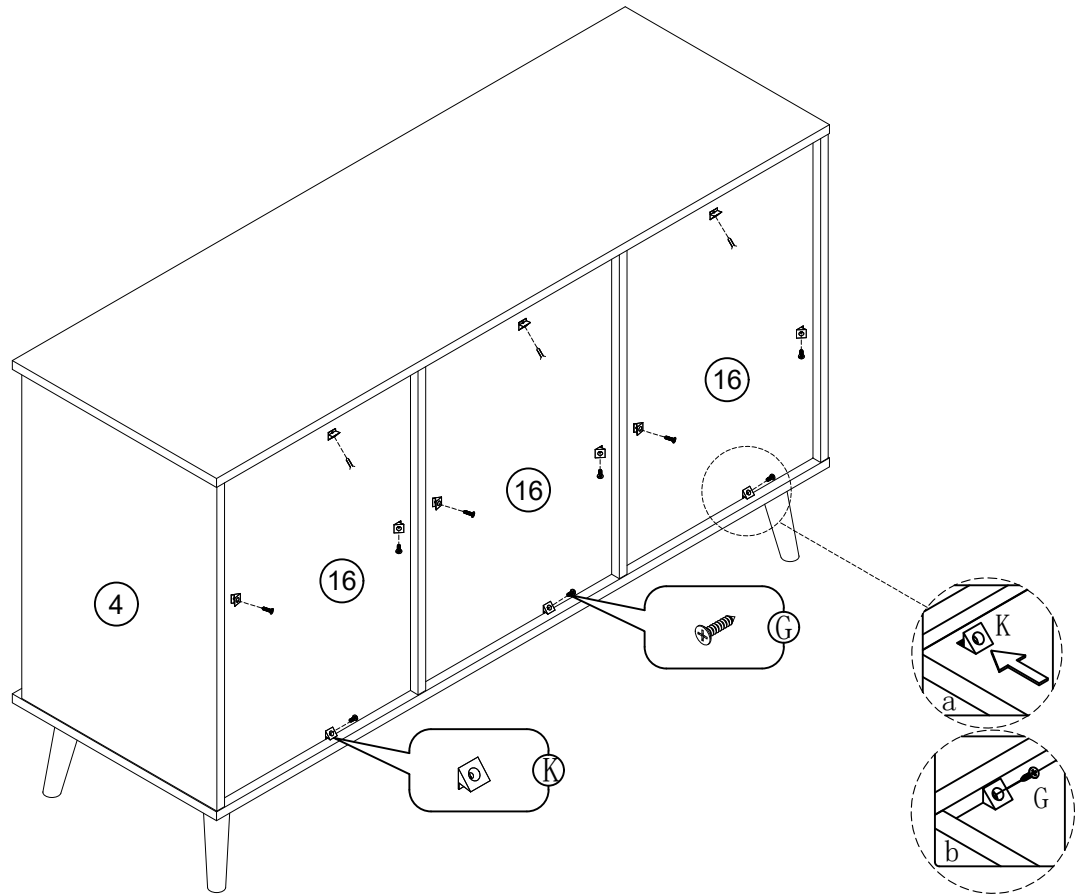
Step 8



	Gx12pcs
	Kx12pcs

Schritt 9

Step 9

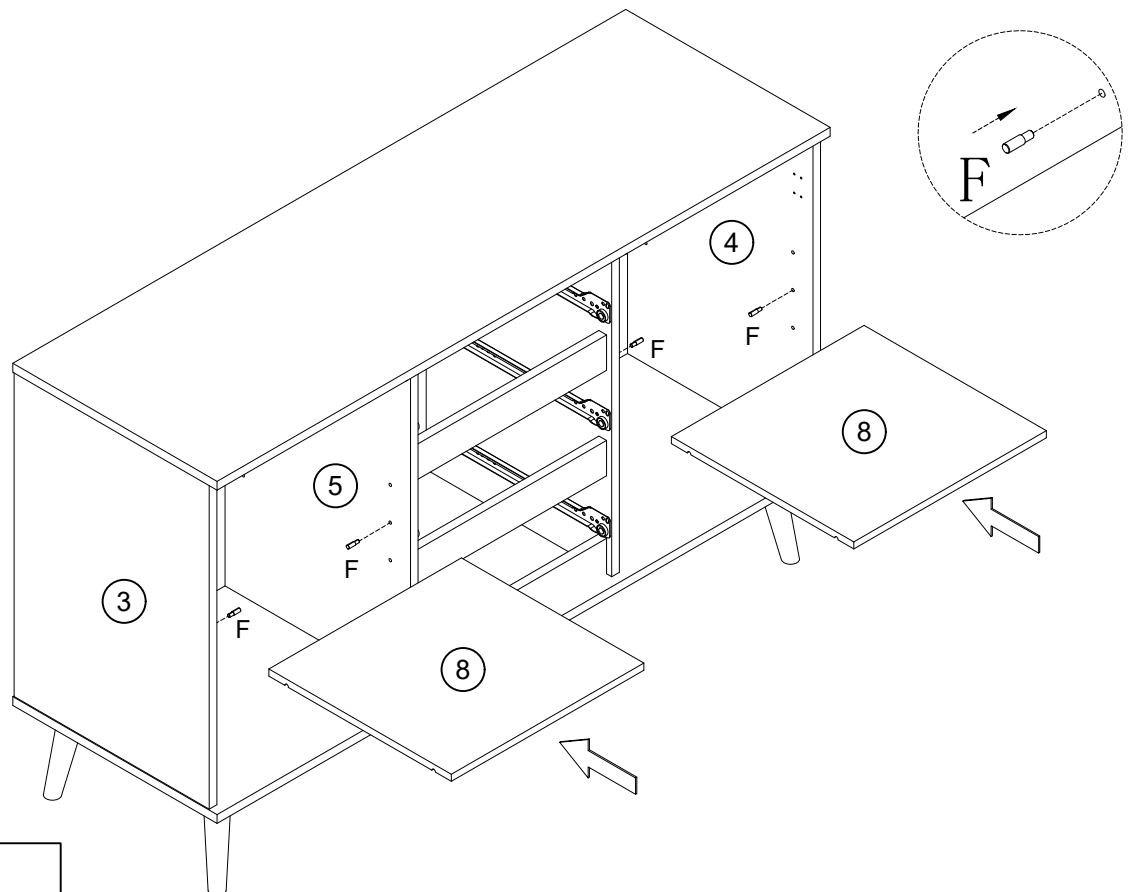



	Fx8pcs
--	--------

Schritt 10

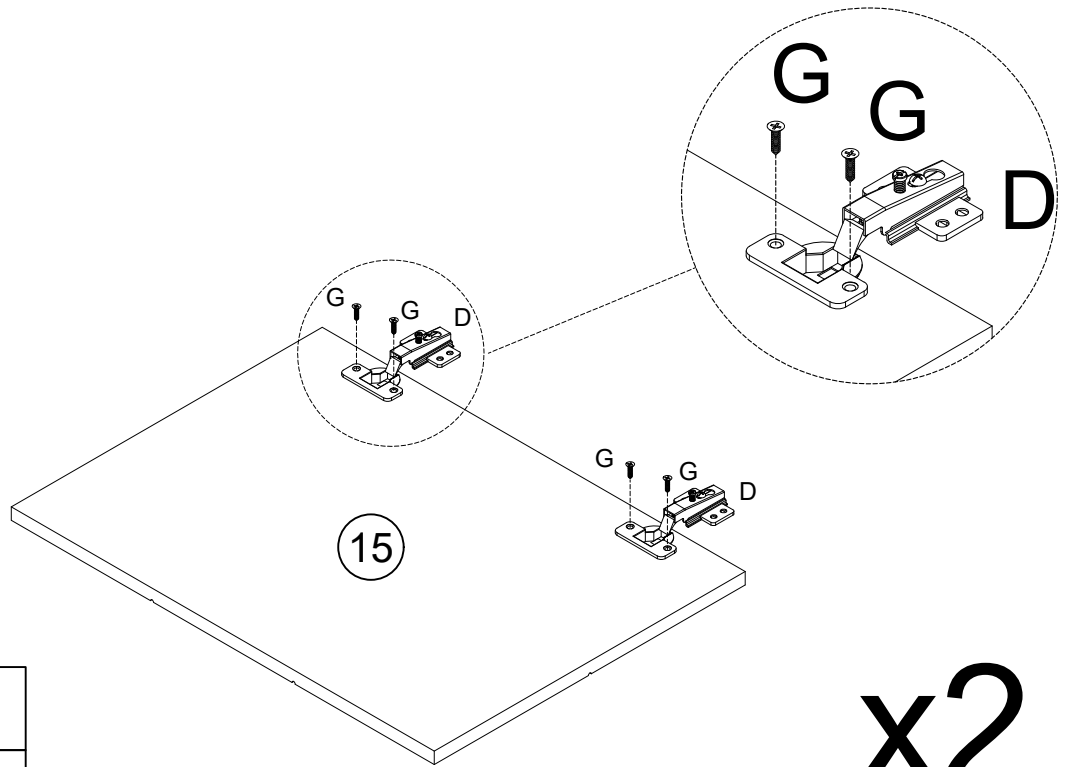
Step 10



	Gx8pcs
	Dx4pcs

x2

Schritt 11

Step 11

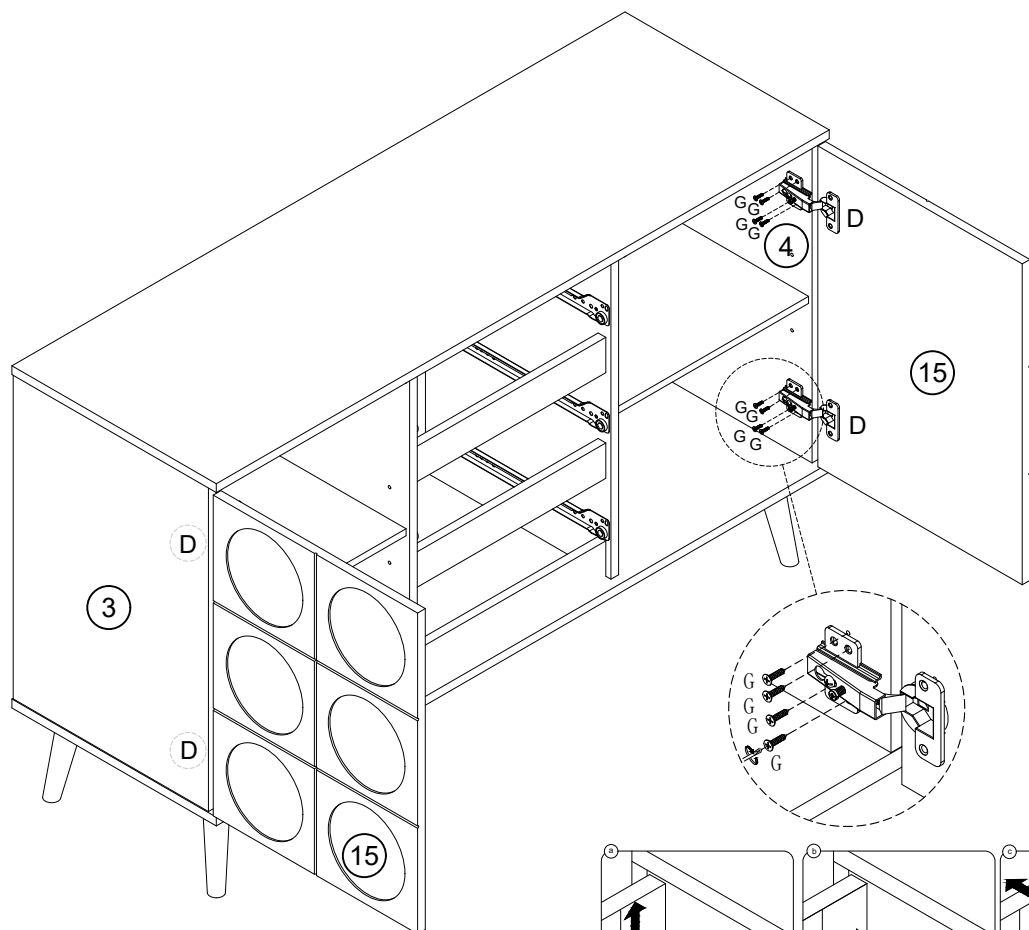

	Gx16pcs
--	---------

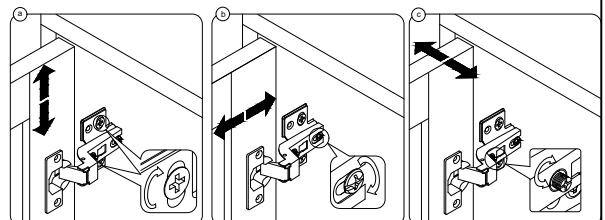

Schritt 12

Step 12

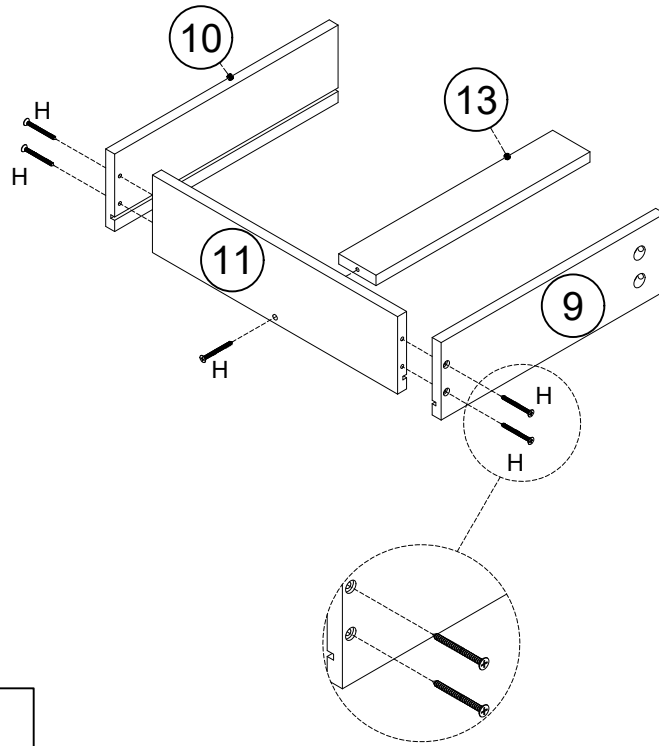

x3



Hx15pcs

Schritt 13

Step 13

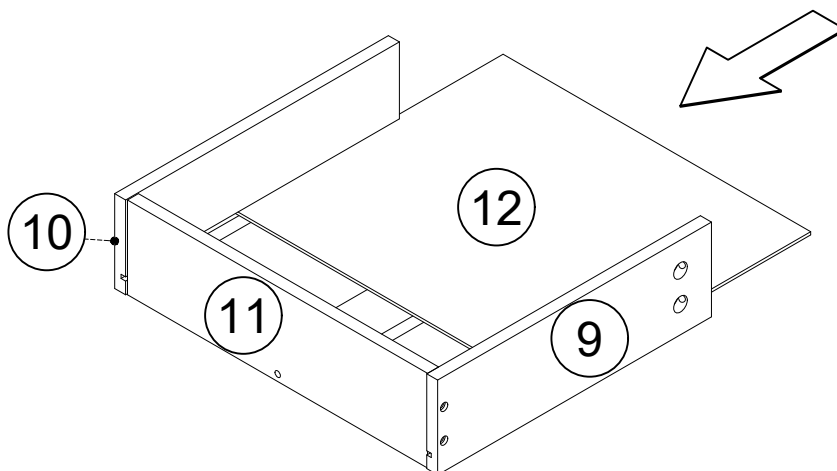

x3

Schritt 14

Step 14

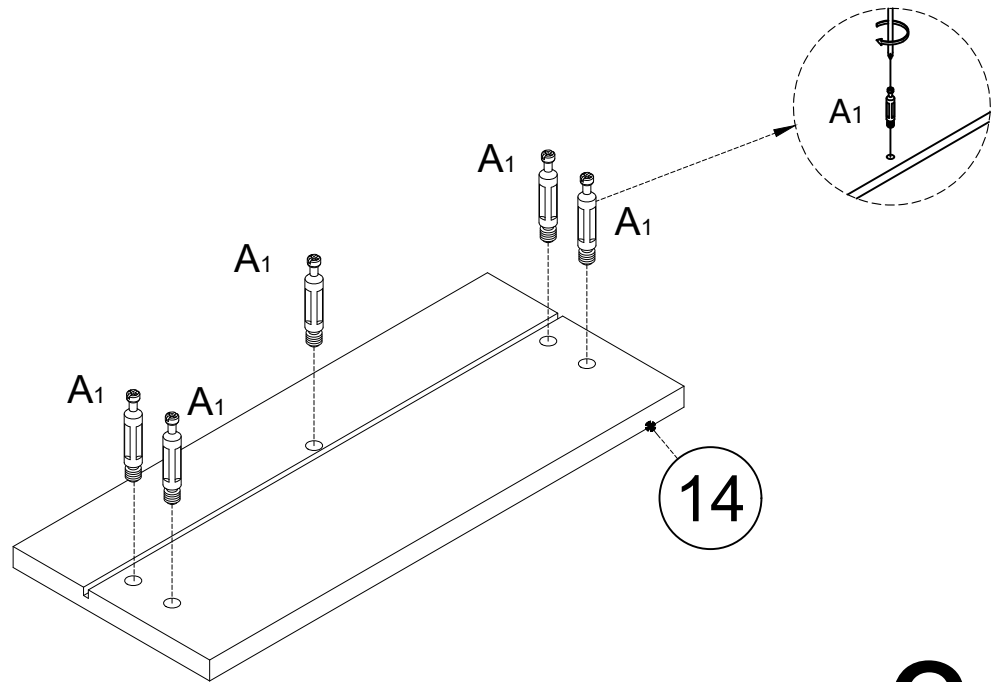

x3



A₁x15pcs

Schritt 15

Step 15

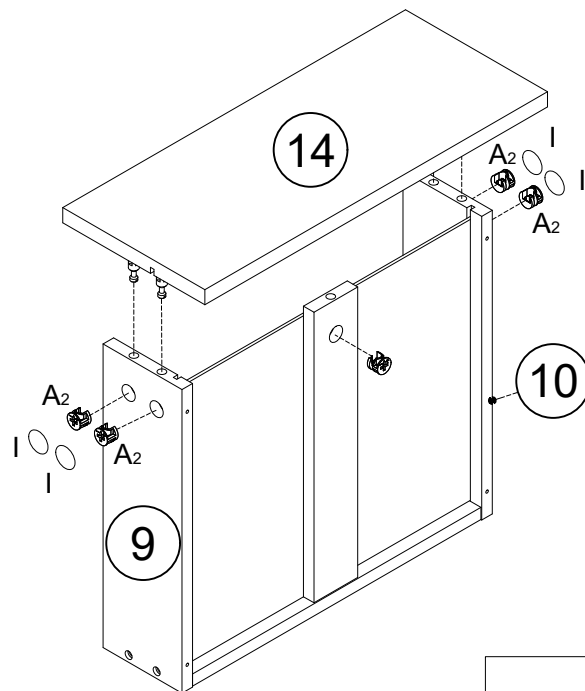

x3



A₂x15pcs





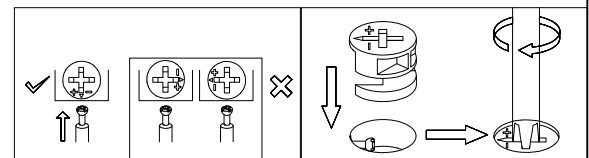

I x12pcs

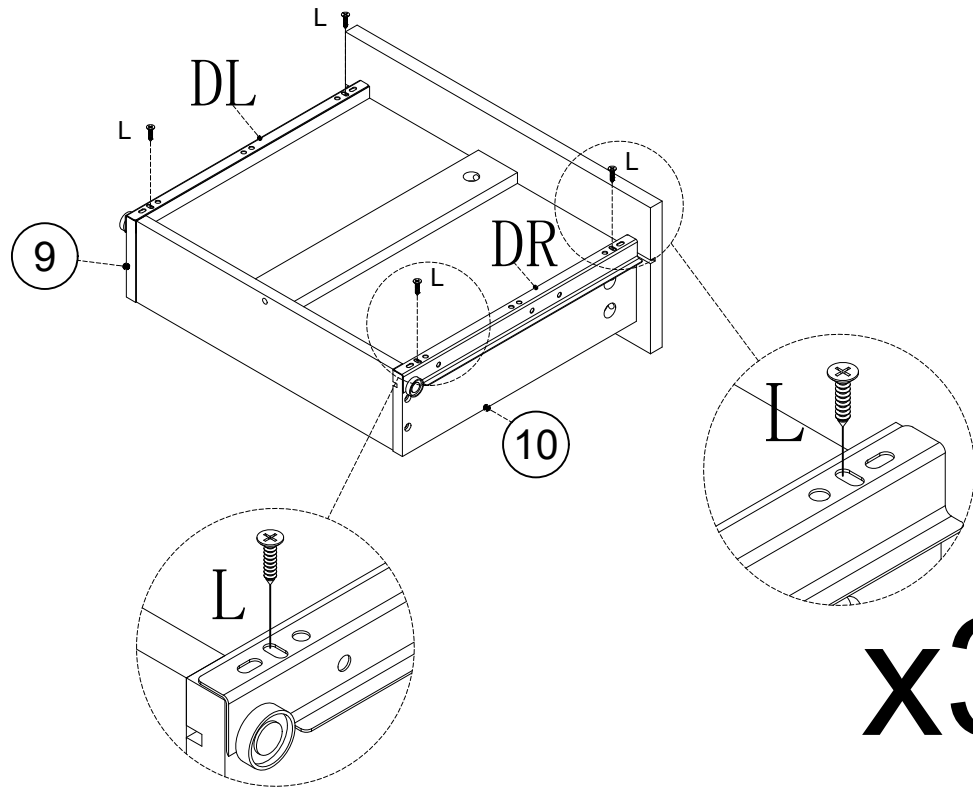

Schritt 16

Step 16



	Lx12pcs
	DRx3pcs
	DLx3pcs

Schritt 17

Step 17

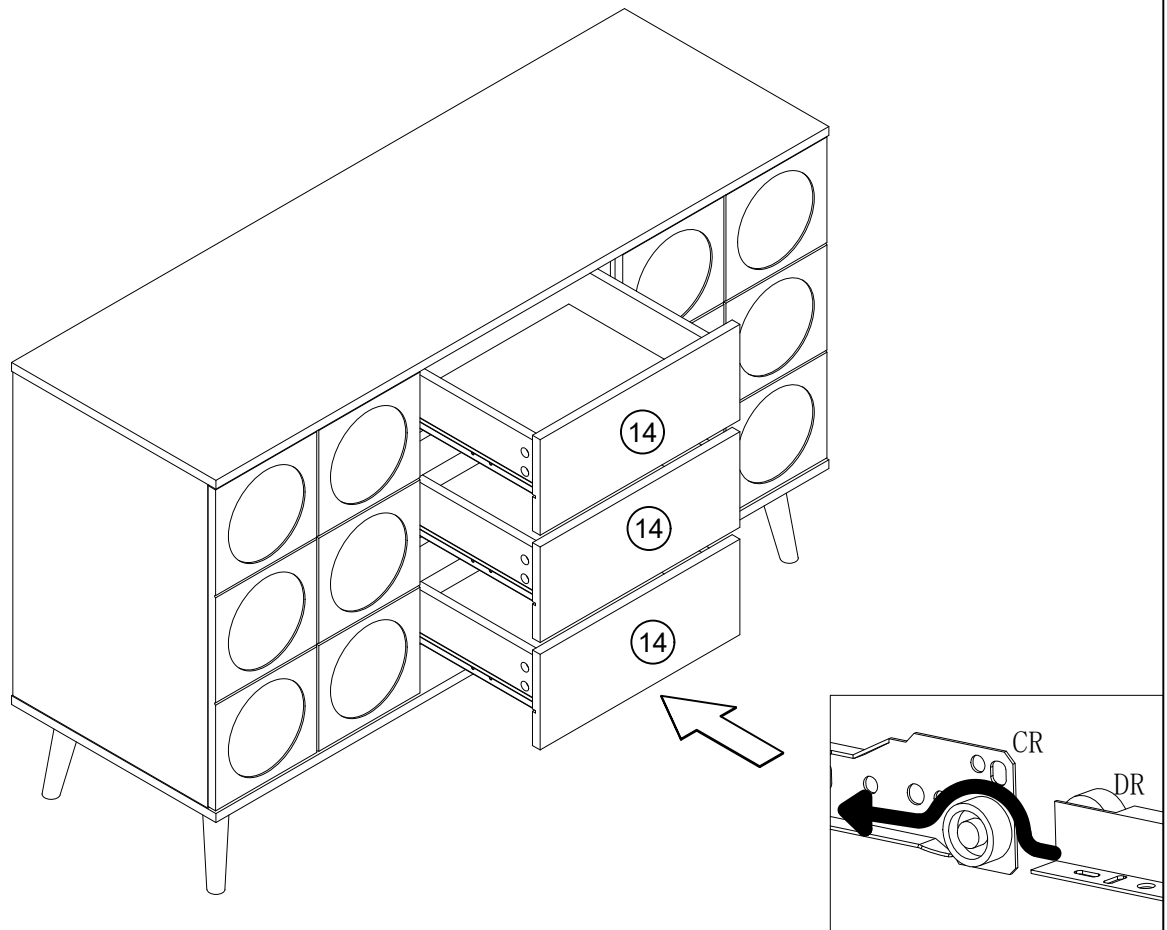

Schritt 18

Step 18

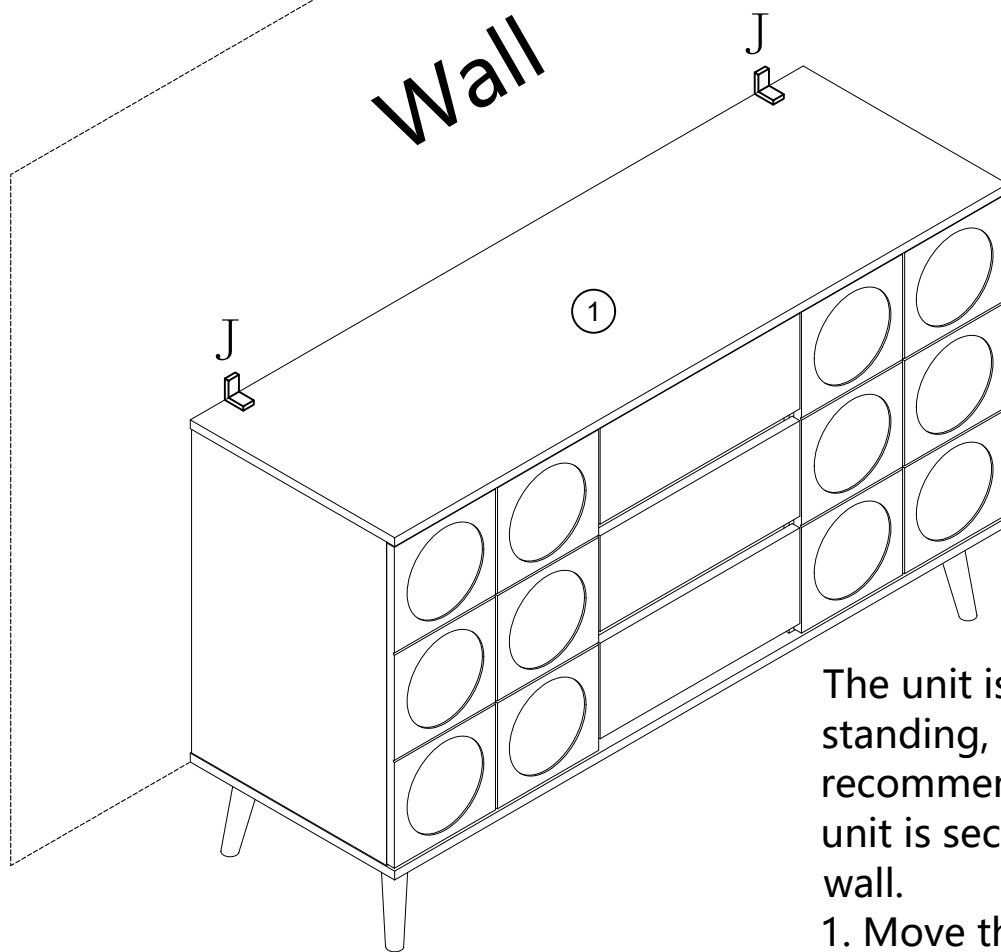
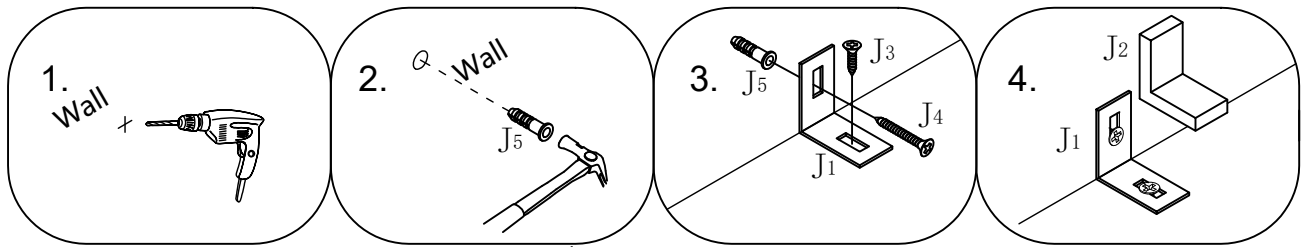





The unit is floor standing, but it is recommended that the unit is secured to the wall.

1. Move the unit into desired position.
2. Mark the wall with a suitable scribe the position of the fixing holes.
3. Drill holes and insert 2 x wall plug



Warning:
Before drilling, check wall for hidden pipes and cables.

	J ₁ x2pcs		J ₃ x2pcs		
	J ₂ x2pcs		J ₄ x2pcs		J ₅ x2pcs